

Tata Steel UK Limited

Shotton Works
Deeside
Flintshire CH5 2NH

Tel: 01244 892459 (Technical enquiries: 01244 892446)
Fax: 01244 892442
e-mail: colorcoaturban@tatasteel.com
website: www.colorcoaturban.com



Agrément Certificate

09/4698

Product Sheet 1

COLORCOAT PANELS

COLORCOAT URBAN ROOF PANEL

This Agrément Certificate Product Sheet⁽¹⁾ relates to the Colorcoat Urban⁽²⁾ Roof Panel, comprising profiled weather protective coated steel panels used in conjunction with a fully supporting continuous layer of OSB/3 or plywood decking for use in residential buildings as a protective/decorative cladding over cold roofs or insulated warm roofs.

- (1) Hereinafter referred to as 'Certificate'.
(2) 'Colorcoat Urban' is a registered trademark of the Certificate holder.

CERTIFICATION INCLUDES:

- factors relating to compliance with Building Regulations where applicable
- factors relating to additional non-regulatory information where applicable
- independently verified technical specification
- assessment criteria and technical investigations
- design considerations
- installation guidance
- regular surveillance of production[†]
- formal three-yearly review.[†]

KEY FACTORS ASSESSED

Strength and stability — the product will resist the wind suction pressures normally experienced in the UK and the deflection will not be excessive under normal service conditions (see section 6).

Behaviour in relation to fire — the product, on an OSB deck, can achieve a B_{ROOF}(t4) classification to BS EN 13501-5 : 2005 and be unrestricted in terms of proximity to a boundary; however, restrictions may apply to other roof assemblies, depending on the material/components used and the overall construction (see section 7).

Weathertightness — the product has adequate resistance to the passage of moisture (see section 8).

Condensation risk — the risk of condensation forming under normal service condition is negligible providing correct construction details are adopted (see section 9).

Durability — the product will have durability for a period in excess of 40 years (see section 11).



The BBA has awarded this Certificate to the company named above for the product described herein. This product has been assessed by the BBA as being fit for its intended use provided it is installed, used and maintained as set out in this Certificate.

On behalf of the British Board of Agrément

Date of Third issue: 11 December 2014

Brian Chamberlain

Originally certificated on 27 November 2009

Head of Approvals — Engineering

Claire Curtis-Thomas

Chief Executive

Certificate amended on 28 January 2016 to include reference to breather membrane in clause 4.2.

Certificate amended on 27 September 2021 to revise section 7.

This Certificate was amended on 22 May 2024 as part of a transition of The BBA Agrément Certificate scheme delivered under the BBA's ISO/IEC 17020 accreditation. This Certificate was issued originally under accreditation to ISO/IEC 17065. Sections marked with the symbol † are not issued under accreditation. Full conversion to the ISO/IEC 17020 format will take place at the next Certificate review. The BBA is a UKAS accredited Inspection Body (No. 4345). Readers MUST check the validity of this Agrément Certificate by either referring to the BBA website or contacting the BBA directly. Any photographs are for illustrative purposes only, do not constitute advice and must not be relied upon.

British Board of Agrément

Bucknalls Lane
Watford
Herts WD25 9BA

©2014

tel: 01923 665300
clientservices@bbacerts.co.uk
www.bbacerts.co.uk

Regulations

In the opinion of the BBA, Colorcoat Urban Roof Panel, if installed, used and maintained in accordance with this Certificate, can satisfy or contribute to satisfying the relevant requirements of the following Building Regulations (the presence of a UK map indicates that the subject is related to the Building Regulations in the region or regions of the UK depicted):



The Building Regulations 2010 (England and Wales) (as amended)

Requirement:	A1	Loading
Comment:		The product is acceptable as set out in sections 6.1 to 6.5 of this Certificate.
Requirement:	B3(2)	Internal fire spread (structure)
Comment:		The product may be restricted by this Requirement. See sections 7.1 to 7.3 of this Certificate.
Requirement:	B4(2)	External fire spread
Comment:		The product may be restricted by this Requirement. See sections 7.1 and 7.2 of this Certificate.
Requirement:	C2(b)(c)	Resistance to moisture
Comment:		The product will contribute to meeting the stated requirements. See sections 8 and 9 of this Certificate.
Regulation:	7	Materials and workmanship
Comment:		The product is acceptable. See sections 11.3 and 11.4 and the <i>Installation</i> part of this Certificate.



The Building (Scotland) Regulations 2004 (as amended)

Regulation:	8(1)(2)	Durability, workmanship and fitness of materials
Comment:		The product will contribute to a construction satisfying this Regulation. See sections 10 and 11.3 and 11.4 and the <i>Installation</i> part of this Certificate.
Regulation:	9	Building standards applicable to construction
Standard:	1.1(a)(b)	Structure
Comment:		The product is acceptable, with reference to clause 1.1.1 ⁽¹⁾ . See sections 6.1 to 6.5 of this Certificate.
Standard:	2.1	Compartmentation
Standard:	2.2	Separation
Standard:	2.3	Structural protection
Comment:		The product may be restricted by these Standards, with reference to clauses 2.1.15 ⁽²⁾ , 2.2.7 ⁽²⁾ , 2.2.10 ⁽¹⁾ and 2.3.5 ⁽¹⁾⁽²⁾ . See sections 7.1 to 7.3 of this Certificate.
Standard:	2.8	Spread from neighbouring buildings
Comment:		The product may be restricted by this Standard, with reference to clause 2.8.1 ⁽¹⁾⁽²⁾ . See sections 7.1 and 7.2 of this Certificate.
Standard:	3.10	Precipitation
Comment:		The product will contribute to meeting this Standard, with reference to clauses 3.10.1 ⁽¹⁾⁽²⁾ , 3.10.5 ⁽¹⁾⁽²⁾ and 3.10.7 ⁽¹⁾⁽²⁾ . See sections 8 and 9 of this Certificate.
Standard:	7.1(a)(b)	Statement of sustainability
Comment:		The product can contribute to satisfying the relevant requirements of Regulation 9, Standards 1 to 6, and therefore will contribute to a construction meeting a bronze level of sustainability as defined in this Standard.

Regulation:	12	Building standards applicable to conversions
Comment:	All comments given for this product under Regulation 9, Standards 1 to 6, also apply to this Regulation, with reference to clause 0.12.1 ⁽¹⁾⁽²⁾ and Schedule 6 ⁽¹⁾⁽²⁾ .	
	(1) Technical Handbook (Domestic).	
	(2) Technical Handbook (Non-Domestic).	



The Building Regulations (Northern Ireland) 2012

Regulation:	23	Fitness of materials and workmanship
Comment:	The product is acceptable. See sections 11.3 and 11.4 and the <i>Installation</i> part of this Certificate.	
Regulation:	28	Resistance to moisture and weather
Comment:	The product will contribute to satisfying this Regulation. See sections 8 and 9 of this Certificate.	
Regulation:	30	Stability
Comment:	The product is acceptable as set out in sections 6.1 to 6.5 of this Certificate.	
Regulation:	35(2)	Internal fire spread - Structure
Comment:	The product may be restricted by this Regulation. See sections 7.1 to 7.3 of this Certificate.	
Regulation:	36(b)	External fire spread
Comment:	The product may be restricted by this Regulation. See sections 7.1 and 7.2 of this Certificate.	

Construction (Design and Management) Regulations 2007

Construction (Design and Management) Regulations (Northern Ireland) 2007

Information in this Certificate may assist the client, CDM co-ordinator, designer and contractors to address their obligations under these Regulations.

See section: *3 Delivery and site handling (3.4 to 3.7)* of this Certificate.

Additional Information

NHBC Standards 2014

NHBC accepts the use of Colorcoat Urban Roof Panel, provided it is installed, used and maintained in accordance with this Certificate, in relation to *NHBC Standards*, Chapter 7.2 *Pitch roofs*.

CE marking

The Certificate holder has taken the responsibility of CE marking the product, in accordance with harmonised European Standard BS EN 14783 : 2006 for the Colorcoat Urban Roof sheets (514 mm and 305 mm cover width). An asterisk (*) appearing in this Certificate indicates that data shown is given in the manufacturer's Declaration of Performance.

Technical Specification

1 Description

1.1 The Colorcoat Urban Roof Panel comprises an outer skin profiled from 0.7 mm thick, Galvalloy treated, grade S220GD steel sheets⁽¹⁾ to BS EN 10346 : 2009. The sheet is treated with a 200 μ HPS 200 plastisol coating on the exposed face and a 10 μ polyester coating on the reverse face.

(1) Covered by BBA Certificate 91/2717.

1.2 The panels are available in maximum length of 12.5 m⁽²⁾ with nominal panel widths of 514 mm and 305 mm with the profile shown in Figure 1.

(2) Length of sheet greater than 12.5 m is available to special order.

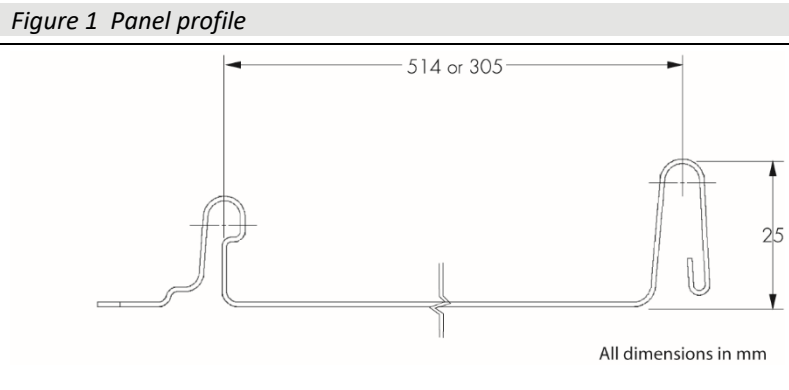

1.3 The panels available in a range of standard colours (see Table 1).

Table 1 Colour range

Colour	Nearest RAL Classic card or Design card or BS Card finish
Winter Sky	RAL 7040
Alaska	RAL 7000
Merlin	BS 18B25
Anthracite	RAL 7016
Terracotta	BS 04C39
Oxidised	RAL 0502010
Patina	RAL 1807025

Note: Additional colours can be produced by the Certificate holder Repertoire colour consultancy service, but the performance of these colours is outside of the scope of the Certificate.

1.4 The Colorcoat Urban Roof Panel characteristics and declared Performance in accordance with BS EN 14783 : 2006 are given in Table 2.

Table 2 Panel characteristics and declared performance

Characteristic	Performance*
Yield strength ($\text{kN}\cdot\text{mm}^{-2}$)	0.7 mm sheet – 220
Tensile strength ($\text{kN}\cdot\text{mm}^{-2}$)	0.7 mm sheet – 300
Elongation (%)	0.7 mm sheet – 20
Water permeability	Impermeable
Dimensional change	$12 \times 10^{-6} \text{ k}^{-1}$
Water vapour and air permeability	Impermeable
Release of dangerous substances	Not classified as dangerous
Durability	Coating S220+ZA255
External Fire performance	$B_{\text{ROOF}}(t_4)$

1.5 Ancillary items for use with the panels and manufactured from the same grade of steel, include verge, eaves and ridge profiles.

1.6 Other specified items used with the panels include:

- breather membrane — for example, Protect ZYTEC (resistance $0.15 \text{ MN}\cdot\text{s}\cdot\text{g}^{-1}$) to BS EN ISO 12572 : 2001
- panel fixings — 3.3 mm diameter 40 mm in length nails (eg Z FRP40W3) or wood screws for fixing panel to support decking.

1.7 Other ancillary items specified for used with the panel but not covered by this Certificate include:

- roof decking — a continuous layer of minimum 15 mm or 18 mm thick OSB3 or plywood to provide fully supported decking under the panels
- Insulation — for use in warm roof construction
- fasteners — clips, screws, nails and installation aids.

2 Manufacture

2.1 The Urban Roof profiles are manufactured from only one coil of raw material in the production process. This is supplied and processed into slit coils and then formed into specified profiles on the roll formers.

2.2 In a coil-coating process, steel coil is degreased, chemically pre-treated and coated on the face and reverse sides and then profiled by roll-forming.

2.3 As part of the assessment and ongoing surveillance of product quality, the BBA has:

- agreed with the manufacturer the quality control procedures and product testing to be undertaken
- assessed and agreed the quality control operated over batches of incoming materials
- monitored the production process and verified that it is in accordance with the documented process
- evaluated the process for management of nonconformities
- checked that equipment has been properly tested and calibrated
- undertaken to carry out the above measures on a regular basis through a surveillance process, to verify that the specifications and quality control operated by the manufacturer are being maintained.

3 Delivery and site handling

3.1 The profiled panels are normally delivered to site in pre-specified lengths according to the dimensions of the roof on which they are to be installed and are palletted in packs of 6 or 4 depending on length and weight. Delivery is normally by lorry and unloading carried out by crane or moffet. The site must have adequate access and a suitable surface for this traffic.

3.2 During transport, the panels must be suitably restrained to prevent abrasion and their edges and corners protected against damage.

3.3 The panels should be stored on a firm, dry base, on bearers with a maximum spacing of 900 mm, away from the possibility of damage, and suitably protected. They should be stored as close as possible to the building where they are to be installed.

3.4 The panels should be handled in accordance with the *Manual Handling Operations Regulations 2004* (revised version). The panels should be lifted from the stack rather than dragged across it.

3.5 When being moved by hand, the panels should be turned and carried on their edge using appropriate personal protective equipment (PPE).

3.6 Where possible, the panels should be lifted manually onto the roof in single sheets. If a hoist is required, only suitable slings or ropes should be used, not chains. Care should be taken to avoid distortion due to bending.

3.7 When working on the roof, soft-soled shoes must be worn. The soles should be checked for any sharp objects that could damage the panel or cause injury.

Assessment and Technical Investigations

The following is a summary of the assessment and technical investigations carried out on Colorcoat Urban Roof Panel.

Design Considerations

4 General

4.1 The Colorcoat Urban Roof Panel is suitable on roofs with a slope of between 5° and 60° as:

- a protective/decorative covering over cold and warm roofs supported on a continuous layer of minimum 15 mm thick OSB/3 or plywood decking for use in residential buildings.
- weather covering to the outer skin of a structural insulated panel system (provided that they have a minimum thickness of 15 mm OSB3/ply board).

4.2 The design of the roof must include:

- a ventilated cavity system incorporating an insect guard to all ventilation openings at the eaves
- an effective breather membrane between the OSB/plywood board and the steel sheets to ensure that the system is protected
- the design thickness of OSB/plywood board and the rafter spacing to cope with wind pressure and greater than 15 mm board must be used if required.

4.3 The panels are dimensionally stable. The fixing arrangement and the recommended construction tolerances will adequately accommodate thermal movements.

4.4 It is important for designers, planners, contractors and/or installers to ensure that the installation of the product is in accordance with the Certificate holder's instructions and the information given in this Certificate.

5 Practicability of installation

The panels should only be installed by roofing contractors whose installers have been trained and approved by the Certificate holder.

6 Strength and stability



6.1 A suitably qualified and experienced individual must check the design and installation of the product fixed onto the substrate in accordance with the relevant national Building Regulations and national Standards.

Wind loading

6.2 Design wind actions should be calculated in accordance with BS EN 1991-1-4 : 2005. Due consideration should be given to the higher-pressure coefficients applicable to edges of the roof as recommended in this Standard.

6.3 The contribution of the sheets and support decking on the stability of the substrate is assumed to be negligible. The supporting roof must be able to take full dead, imposed, wind actions and any racking loads on its own as no contribution from the sheeting may be assumed in this respect. The adequacy of the substrate is outside the scope of this Certificate and must be verified by a suitably qualified and experienced individual.

6.4 The characteristic pull-out resistance of the fixing was carried out on the 18 mm OSB board and was calculated from pull-out failure value (determined by tests) and is given in Table 3.

Table 3 Characteristic pull-out resistance (kN)

Fixing Type	Thickness of OSB3 board (mm)	Characteristic Resistance (kN)
Z-FRP40W3	15	0.88
Z-FRP40W3	18	1.10

6.5 The ultimate resistance and wind load resistance values have been confirmed from calculations given in Table 4.

Table 4 Ultimate resistance and wind load resistance values

Characteristic (units)	Panel width (mm)	
	305	514
ultimate resistance (kN·m ²)	3.86	0.48
wind load resistance (kN·m ²)	2.57	0.32

Note:

Allowing for a normal wind load factor of 1.5 on the ultimate resistance value, provided the designer ensures:

- fixing centres do not exceed 200 mm, and the panels will have adequate flexural resistance against all wind succession pressure likely to be experienced in the UK
- design of the panel must be such as to limit the mid-span deflections under succession pressure to L/90 or 10 mm, whichever is the lesser.

Impact loading

6.6 In low pitch roofs between 5° to 9° and in high wind areas, the recommended panel width to be used is 305 mm panel to prevent any possibility of water ingress through the seam, due to heavy rain and ponding. The manufacturer’s guidance manual on all panel width selection is dependent on location, and storey height in the UK and must be followed by the installers of the panels.

Acoustics due to high winds

6.7 In very high winds condition, drumming can occur and to minimise this occurrence, the mid-span deflection shall be limited to 10 mm. The manufacturer’s guidance manual on all panel width selection dependant on location, and storey height in the UK and must be followed by the installers of the panels.

7 Behaviour in relation to fire



7.1 When tested, a construction incorporating the product achieved the classifications shown in Table 5 and is therefore unrestricted in terms of proximity to a boundary. See also section 7.2 of this Certificate.

Table 5 Resistance to external fire exposure

Classification	Method	Construction ⁽¹⁾	Report reference
EXT.S.AB ⁽¹⁾	BS 476-3 : 2004	0.7 mm grey Colorcoat Urban roof panel, breather membrane and 18 mm OSB/3	BRE P111132-1000 26 March 2018
B _{ROOF} (t4) ⁽¹⁾	CEN/TS 1187 : 2012 and EN 13501-5 : 2005	0.7 mm grey Colorcoat Urban roof panel, breather membrane and 18 mm OSB/3	BRE P111132-1002 26 March 2018

(1) roof pitches greater than 10°.



7.2 This designation may not be achieved by other colours or constructions and can also be affected by other components of the roof, eg SIP panels. These constructions should therefore be evaluated by reference to the requirements of the documents supporting the relevant national Building Regulations and any consequent restrictions imposed by those documents, on a case-by-case basis. In the absence of a designation, these constructions should not be used within 20 metres of a boundary in England, Wales and Northern Ireland, and 24 metres in Scotland.

7.3 Where the products are to be carried over compartment walls, designers must ensure that the roof/wall junction detail provides sufficient resistance to fire penetrating into the neighbouring compartment.

7.4 Designers should refer to the relevant national Building Regulations and guidance for detailed conditions of use, particularly in respect of requirements for substrate fire performance, cavity barriers, service penetrations and combustibility limitations for other materials and components used in the overall construction.

8 Weathertightness



The panels, when incorporated into a roof system designed and installed in accordance with conventional good practice will adequately resist the passage of moisture as described in section 9.2 of this Certificate.

9 Condensation risk



9.1 In common with all metal roof constructions, there is a risk of condensation. This can arise as either interstitial condensation within the roof construction or surface condensation at thermal bridges.

9.2 To prevent condensation forming between the metal sheets and the substrate, measures should be taken to minimise water vapour reaching the OSB board by incorporating:

- a vapour control layer (VCL) in the roof construction and providing an adequate seal around the ceiling
- a breather membrane in the roof construction to allow the air to circulate freely.

10 Maintenance



10.1 Annual maintenance inspections should be carried out to ensure that all rain ware is present and in good order, flashings are secure and pans are in place and secure.

10.2 Maintenance painting should be considered approximately every 30 years for inland areas and 25 years for coastal areas, or earlier if inspections show this to be necessary or if a higher aesthetic standard is required. For suitable paint systems, the advice of the Certificate holder should be sought.

10.3 In some areas (eg coastal and industrial), it may be necessary to clean the installation periodically, both to restore its appearance and to remove potentially corrosive deposits. Hosing with a neutral detergent diluted with water is an effective method.

10.4 Damaged panels should be replaced as soon as is practicable, in accordance with the Certificate holder's instructions. Special tools are available to assist in the replacement of complete panels. Access to an individual panel for the purpose of replacement will require the prior removal of all panels located on either side back to the edge of the wall.

11 Durability

11.1 The performance of the panel coating will depend on its environment, location, and degree of exposure. The product will retain a good appearance for the intervals given in section 10.2 of this Certificate.

11.2 The urban roof panel, and continuous ridge-to-eaves construction, will minimise exposure of any cut edges which may otherwise be susceptible to corrosion.



11.3 The panel is resistant to all normal atmospheric corrosive agents (including those found in coastal and industrial locations) and will withstand considerable distortion without loss of adhesion between the Colorcoat Urban coating, the primer and the steel substrate.

11.4 The surface treatment on Colorcoat Urban Roof Panels will protect the steel substrate against corrosion for a period in excess of 40 years in normal industrial, urban, suburban and rural environments.

11.5 After natural weathering, slight initial dulling of the surface and slight change in colour shade may occur, particularly on the dark coloured material. However, this process is not likely to be progressive.

12 Reuse and recyclability

The steel material of the product can be fully recycled.

Installation

13 General

13.1 Colorcoat Urban Roof Panels must be installed in accordance with the Certificate holder's recommendations, the requirements of this Certificate and specifications laid down by the consulting engineer. Typical installations are shown in Figure 2.

Figure 2 Typical installation

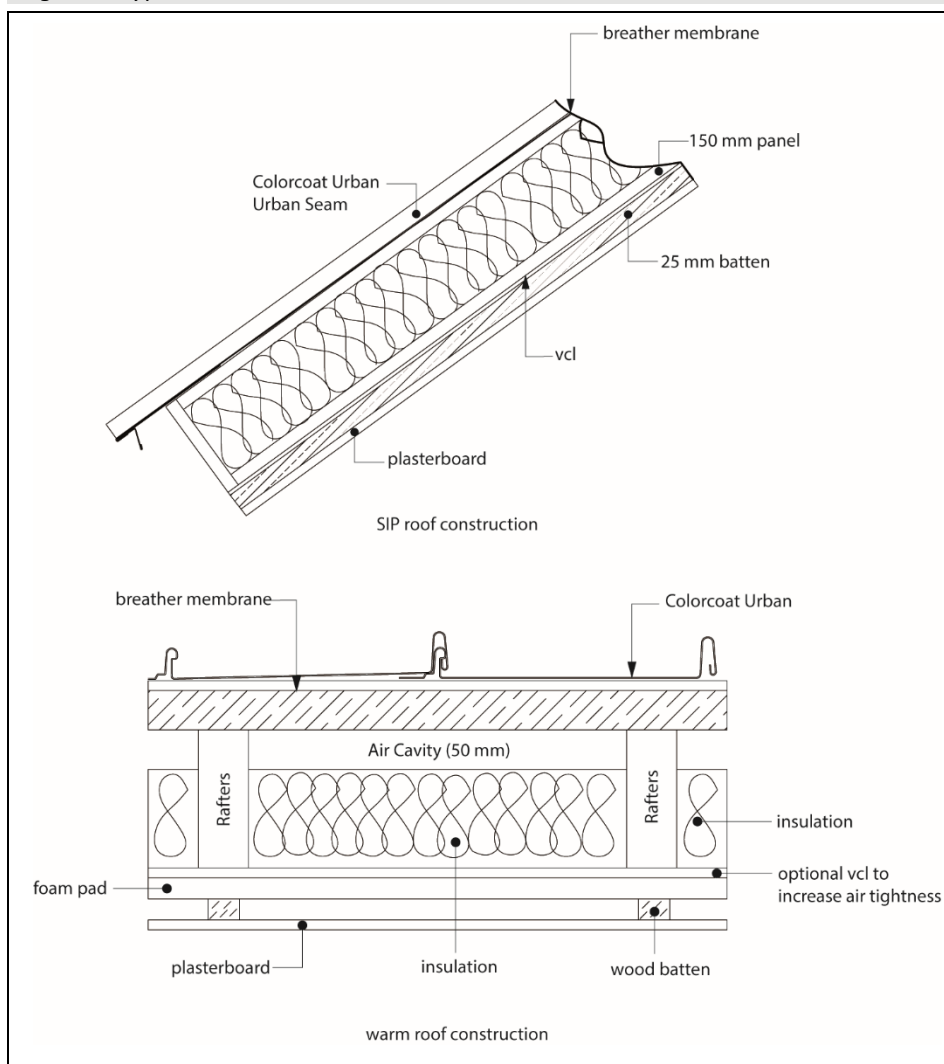

13.2 Installers must be trained and approved by the Certificate holder who can provide technical assistance at the design stage and at the start of the installation, and supply the necessary equipment.

14 Procedure

14.1 Roof dimensions are checked against the drawings, and for squareness. The ridge, eaves and verge dimensions are similarly checked.

14.2 The eaves, verge and ridge backing plates (monopitch) should be in place before installing the panels.

14.3 Working from the right-hand end of the roof (as viewed from ground level), the first panel is installed with the upturned rib in line with the wall edge and its nail strip on the left (see Figure 3).

14.4 The next panel is clipped onto the first and secured to the roof at the predetermined fixing centres, ensuring its rib is parallel with that of the first. Subsequent panels are similarly fitted.

14.5 To allow for thermal movement, the fixings should be of the correct size, located centrally in the nail strip holes with adequate clearance, and should not bear too tightly against the plate.

14.6 Once the penultimate panel has been installed, the left hand end panel can be fitted to suit the roof edge, and the verge detail completed.

14.7 To minimise thermal expansion in hot, sunny weather, the panels should be protected from direct sunlight until ready for use. Conversely, when installing in cold weather, the panels may be 'stretched' against the previously installed panel rib before fixing down.

14.8 When installing in hot weather, adequate clearance should be provided between the folded panel edge. This will allow for contraction due to subsequent decrease in ambient temperature.

14.9 To ensure good weathertightness and efficient rainwater run-off, all components such as edge details and sealants should be used in accordance with the Certificate holder's specifications and instructions.

Figure 3 Fixing details

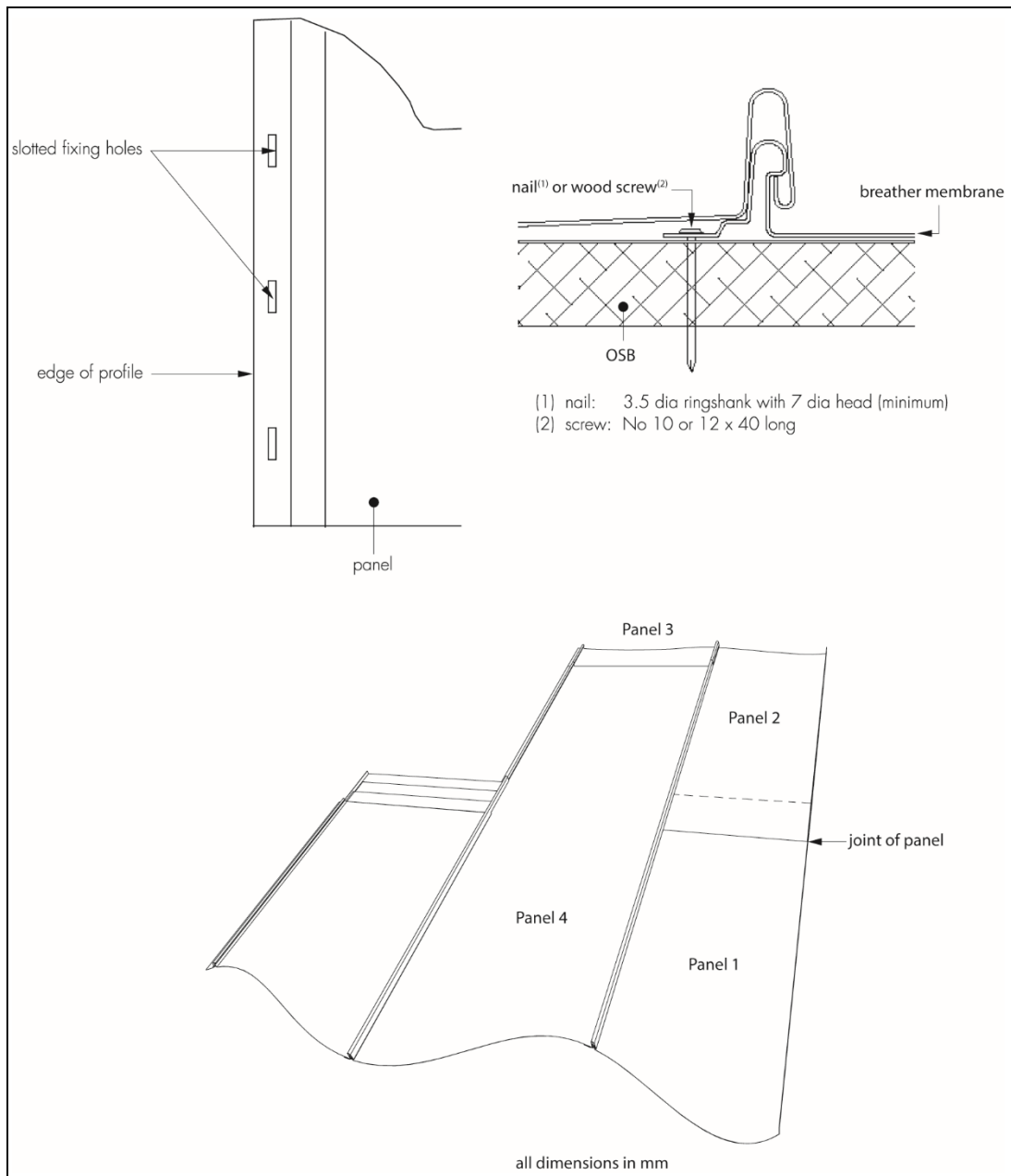

Technical Investigations

15 Test

Based on test data (carried out under BBA Certificate 91/2717) an assessment was made of the panel's performance in relation to:

- wind uplift
- behaviour under thermal actions
- structural ability of fixings onto OSB board
- impact
- reaction to fire
- rain penetration
- durability.

16 Investigations

16.1 An assessment was made of the production method and associated quality control procedures at the manufacturing site.

16.2 The Certificate holder's technical literature was examined for any inconsistencies and general content.

Bibliography

BS 476-3 : 2004 *Fire tests on building materials and structures — Classification and method of test for external fire exposure to roofs*

BS EN 1991-1-4 : 2005 *Eurocode 1 : Actions on structures — General actions — Wind actions*

BS EN 10346 : 2009 *Continuously hot-dip coated steel flat products — Technical delivery conditions*

BS EN 13501-5 : 2005 + A1 : 2009 *Fire classification of construction products and building elements — Classification using data from external fire exposure to roofs tests*

BS EN 14783 : 2006 *Fully supported metal sheet and strip for roofing, external cladding and internal lining — Product specification and requirements*

BS EN ISO 12572 : 2001 *Hygrothermal performance of building materials and products — Determination of water vapour transmission properties*

CEN/TS 1187 : 2012 *Test methods for external fire exposure to roofs*

Conditions of Certificate

Conditions

1. This Certificate:

- relates only to the product that is named and described on the front page
- is issued only to the company, firm, organisation or person named on the front page – no other company, firm, organisation or person may hold or claim that this Certificate has been issued to them
- is valid only within the UK
- has to be read, considered and used as a whole document – it may be misleading and will be incomplete to be selective
- is copyright of the BBA
- is subject to English Law.

2. Publications, documents, specifications, legislation, regulations, standards and the like referenced in this Certificate are those that were current and/or deemed relevant by the BBA at the date of issue or reissue of this Certificate.

3 This Certificate will be displayed on the BBA website, and the Certificate Holder is entitled to use the Certificate and Certificate logo, provided that the product and its manufacture and/or fabrication, including all related and relevant parts and processes thereof:

- are maintained at or above the levels which have been assessed and found to be satisfactory by the BBA
- continue to be checked as and when deemed appropriate by the BBA under arrangements that it will determine
- are reviewed by the BBA as and when it considers appropriate.

4. The BBA has used due skill, care and diligence in preparing this Certificate, but no warranty is provided.

5. In issuing this Certificate the BBA is not responsible and is excluded from any liability to any company, firm, organisation or person, for any matters arising directly or indirectly from:

- the presence or absence of any patent, intellectual property or similar rights subsisting in the product or any other product
- the right of the Certificate holder to manufacture, supply, install, maintain or market the product
- actual installations of the product, including their nature, design, methods, performance, workmanship and maintenance
- any works and constructions in which the product is installed, including their nature, design, methods, performance, workmanship and maintenance
- any loss or damage, including personal injury, howsoever caused by the product, including its manufacture, supply, installation, use, maintenance and removal
- any claims by the manufacturer relating to UKCA, UKNI or CE marking.

6. Any information relating to the manufacture, supply, installation, use, maintenance and removal of this product which is contained or referred to in this Certificate is the minimum required to be met when the product is manufactured, supplied, installed, used, maintained and removed. It does not purport in any way to restate the requirements of the Health and Safety at Work etc. Act 1974, or of any other statutory, common law or other duty which may exist at the date of issue or reissue of this Certificate; nor is conformity with such information to be taken as satisfying the requirements of the 1974 Act or of any statutory, common law or other duty of care.

British Board of Agrément

1st Floor, Building 3, Hatters Lane
Croxley Park, Watford
Herts WD18 8YG

©2024

tel: 01923 665300
clientservices@bbacerts.co.uk
www.bbacerts.co.uk